

**CARGA DE BATERIA • BATTERY RECHARGE • CHARGE DE LA BATTERIE • AUFLADUNG DER BATTERIE • DE ACCU-OPLADER • CARGA DE BATERIA • CARICA DELLA BATTERIA** شحن البطارية



- REALIZAR POR UN ADULTO
- THIS SHOULD BE DONE BY AN ADULT
- A RÉALISER PAR UN ADULTE
- DIES IST VON EINEM ERWACHSENEN AUSZUFÜHREN
- UIT TE VOEREN DOOR EEN VOLWASSENE
- A REALIZAR POR UM ADULTO
- DEVE REALIZARLO UN ADULTO



- POR FAVOR, SIGA EstrictAMENTE LA SECUENCIA DE RECARGA DE LA BATERIA.
  - PLEASE FOLLOW CAREFULLY THE INSTRUCTIONS FOR RE-CHARGING THE BATTERY; FAILURE TO COMPLY WITH THIS PROCEDURE WILL DAMAGE THE BATTERY. THE BATTERY IS NOT COVERED UNDER THE WARRANTY.
  - VEUILLEZ SUIVRE À LA LETTRE SCRUPULEUSEMENT LA PROCÉDURE DE RECHARGEMENT DE LA BATTERIE.
  - BEI DER AUFLADUNG DER BATTERIE FOLGEN SIE BITTE GENAUESTENS DER REIHENFOLGE.
  - VOLG A.U.B. DE OPLAADVOLGORDE VAN DE BATTERIJ STRIKT OP
  - POR FAVOR, SIGA ATENTAMENTE A SECUENCIA DE RECARGA DA BATERIA.
  - PER FAVORE SEGUA ATTENTAMENTE LA SEQUENZA DELLA RICARICA DELLA BATTERIA.
- يرجى اتباع تسلسل عملية إعادة شحن البطارية بدقة.

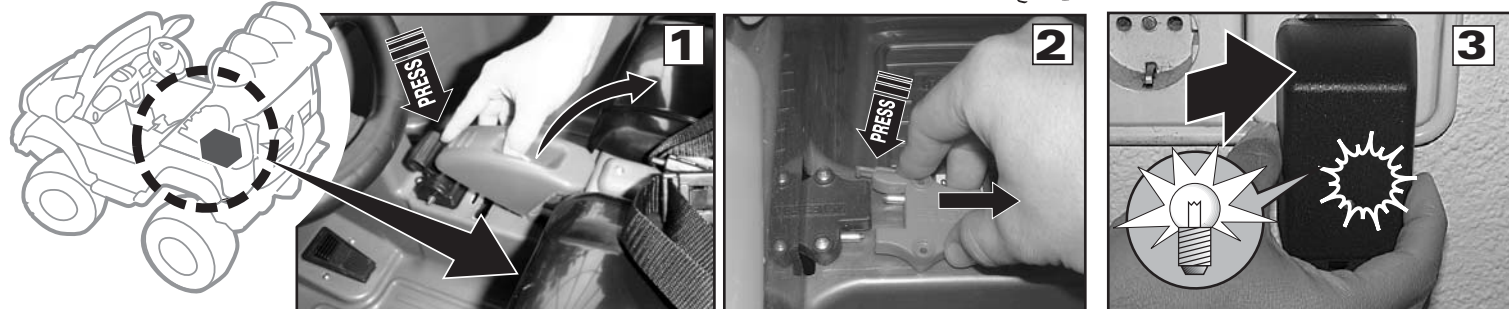

**4**

**EL TIEMPO DE DURACION DE LA RECARGA ES (HORAS):**  
 • RECHARGING TIME IS (HOURS):  
 • LA DURÉE DE LA RECHARGE EST D'ENVIRON (HEURES):  
 • DIE LADEZEIT IST VON (STUNDEN):  
 • OPLAAD-TIJD (UUR):  
 • O TIEMPO DE DURAÇÃO DA RECARGA É (HORAS):  
 • IL TEMPO DI DURATA DELLA RICARICA È (ORE):  
 • مدة مفعولية الشحن بالساعات:  
 (تقريباً)

**14-17** (APPROX.)

QUANDO LA LUZ PILOTO SE VUELVA ENCENDER, LA BATERIA ESTARÁ CARGADA.  
 ONCE THE BATTERY HAS BEEN CHARGED, THE CHARGER PILOT WILL TURN ON.  
 QUAND LA BATTERIE SERA ENTIEREMENT CHARGÉE, LA LUMIÈRE SE RALLUMERA AUTOMATIQUEMENT.  
 WENN DAS SIGNALLICHT WIEDER AUFLEUCHTET IST DIE BATTERIE AUFGELADEN.  
 WANNEER HET LICHTJE TERUG GAAT BRANDEN, IS DE BATTERIJ VOLLEDIG OPGELADEN.  
 QUANDO A LUZ PILOTO SE VOLTAR AACENDER, A BATERIA ESTARÁ CARGADA.  
 QUANDO LA SPIA SI ACCENDE DI NUOVO, LA BATTERIA SARÀ CARICA.  
 عندما تضئ الإشارة الضوئية من جديد تكون البطارية قد شحنت تماما.

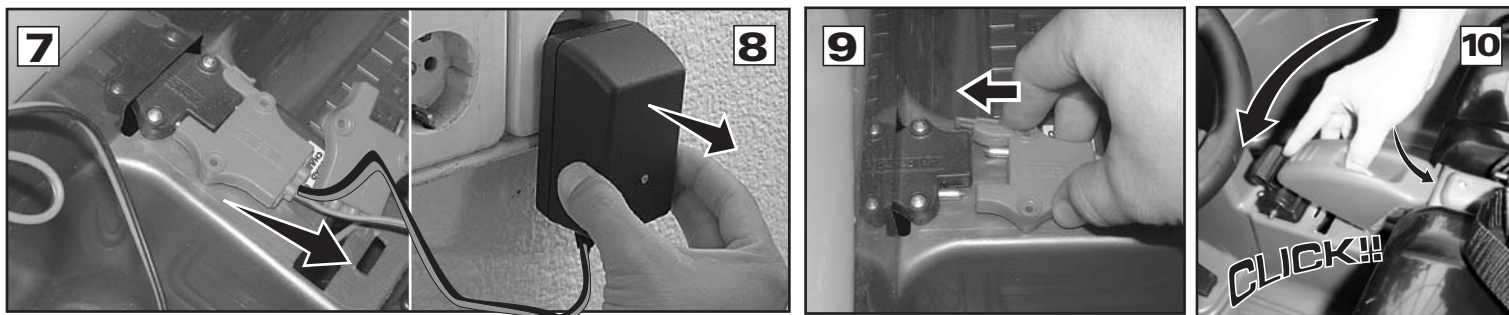

**SUSTITUCIÓN DE LA BATERÍA USADA • REMOVE EXHAUSTED BATTERIES FROM THE TOY • CHANGEMENT DE LA BATTERIE USAGÉE DU JOUET • DIE ERSETZUNG DER GEBRAUCHTEN BATTERIE • ERVANGING VAN DE GEBRUIKTE BATTERIJ • SUBSTITUIÇÃO DA BATERIA USADA • SOSTITUZIONE DELLA BATTERIA USATA**



- REALIZAR POR UN ADULTO
- THIS SHOULD BE DONE BY AN ADULT
- A RÉALISER PAR UN ADULTE
- DIES IST VON EINEM ERWACHSENEN AUSZUFÜHREN
- UIT TE VOEREN DOOR EEN VOLWASSENE
- A REALIZAR POR UM ADULTO
- DEVE REALIZARLO UN ADULTO



- ¡ADVERTENCIA!: NO CORTOCIRCUITAR LA BATERIA.
- WARNING!: NOT TO SHORT-CIRCUIT SUPPLY TERMINALS
- ATTENTION! NE PAS COURT-CIRCUITER LES BORNES DE L'ACCUMULATEUR
- WARNUNG! BATTERIEN NICHT KURZSCHLIEßEN.
- WAARSCHUWING!: DE BATTERIJ NIET KORTSLUITEN.
- AVISO!: NÃO PROVOCAR CURTO-CIRCUITO NA BATERIA.
- AVVERTENZA!: NON FAR FAR CORTO CIRCUITO ALLA BATTERIA.

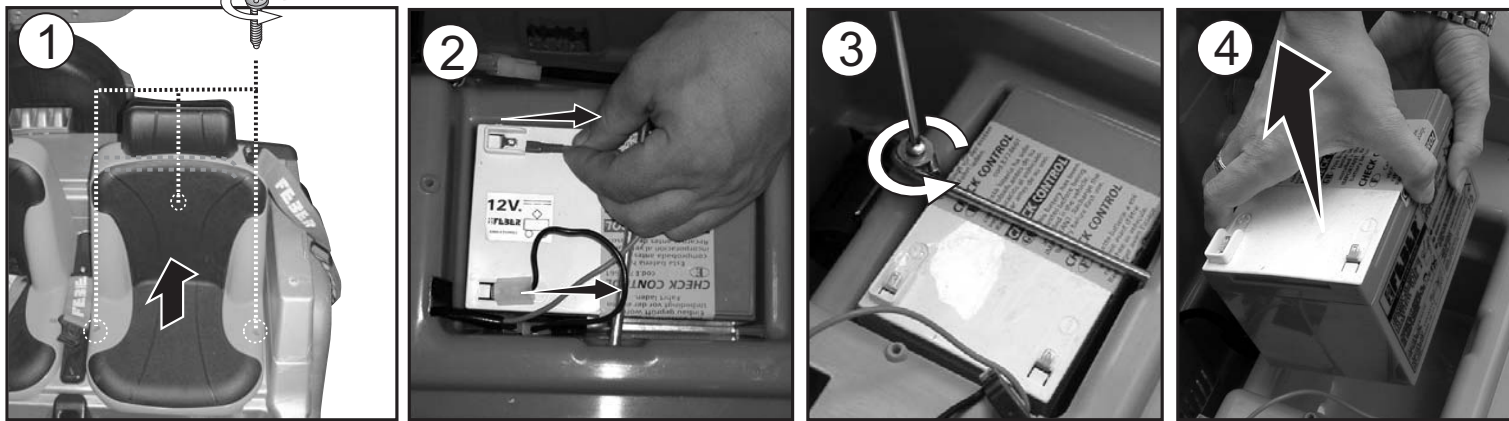

PESO MÁXIMO RECOMENDADO: RECOMMENDED MAXIMUM WEIGHT: POIDS MAX. RECOMMANDÉ: EMPFOHLENES GEWICHT: MAXIMUM AANBEVOLEN GEWICHT: PESO MAXIMO RECOMENDADO: PESO MASSIMO RACCOMANDATO: MAKSIMUM ANBEFALET VÆGT: HÖGST REKOMMENDERAD VIKT: VEILENDE MAKSIMUMVEKT: SUOSITELTU ENIMMÄSPAINO: **50kg** النقل الأقصى الموصى به

TIEMPO DE JUEGO: RUNNING TIME: DURÉE DE FONCTIONNEMENT: SPIELZEIT: RIJTTIJD: TEMPO DE JOGO: TEMPO DI GIOCO: **1h30'** (APPROX.) (مدة اللعب: تقريباً)

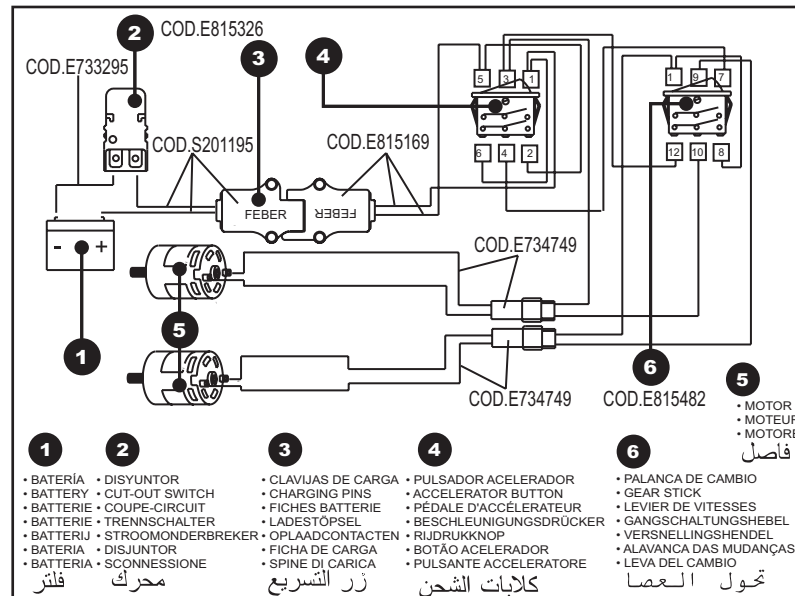

**CONTENIDO • CONTENTS • CONTENU • INHALT • INHOUD • CONTEÚDO • CONTENUTO** INDHOLD • INNEHÅLL • INNHOLD • SISÄLTÖ • المحتوى

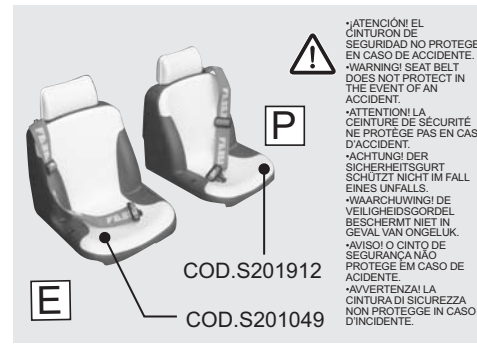
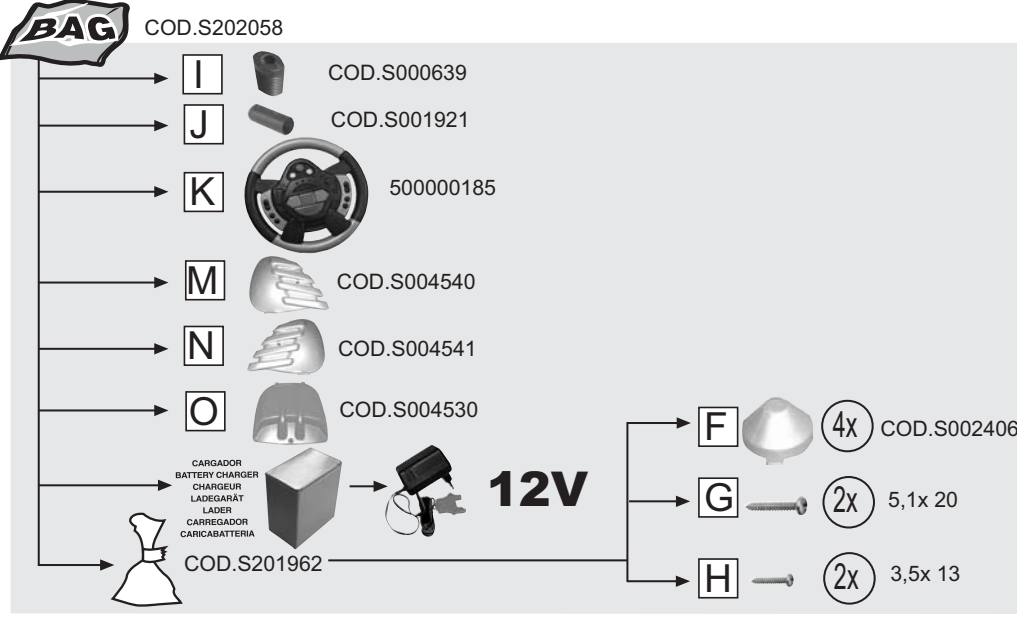
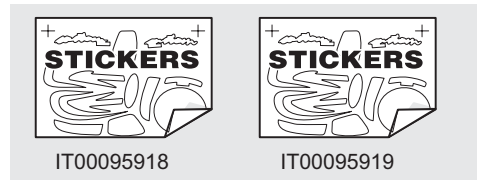
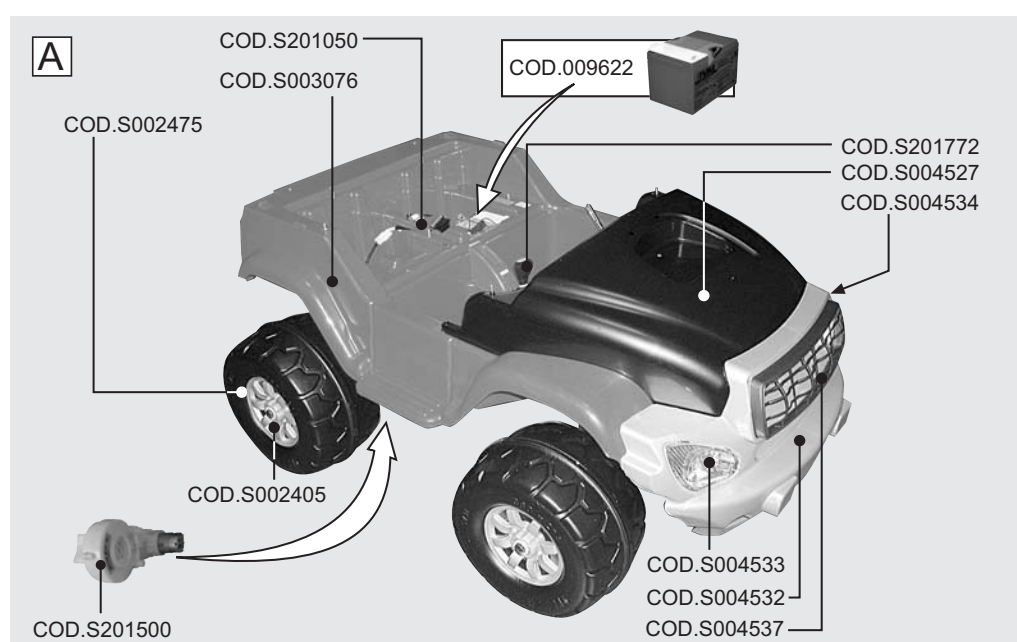



MONTAJE • ASSEMBLY • ASSEMBLAGE • BEDIENUNGSANLEITUNG • MONTAGE  
 • MONTAGEM • MONTAGGIO • MONTERING • KOKOONPANO • التركيب



•REALIZAR POR UN ADULTO  
 •THIS SHOULD BE DONE BY AN ADULT  
 •A RÉALISER PAR UN ADULTE  
 •DIES IST VON EINEM ERWACHSENEN AUSZUFÜHREN  
 •UIT TE VOEREN DOOR EEN VOLWASSENE

•A REALIZAR POR UM ADULTO  
 •DEVE REALIZARLO UN ADULTO  
 يقوم بالعمل شخص بالغ

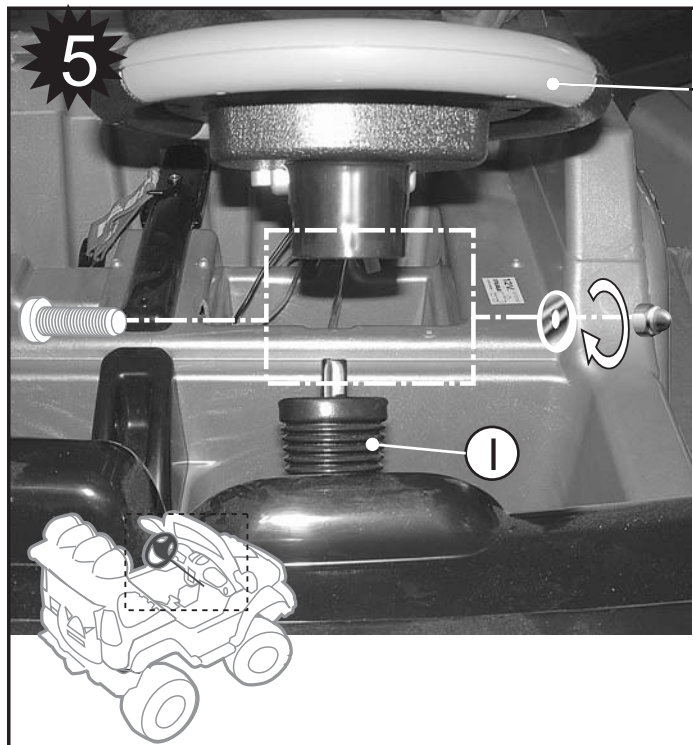
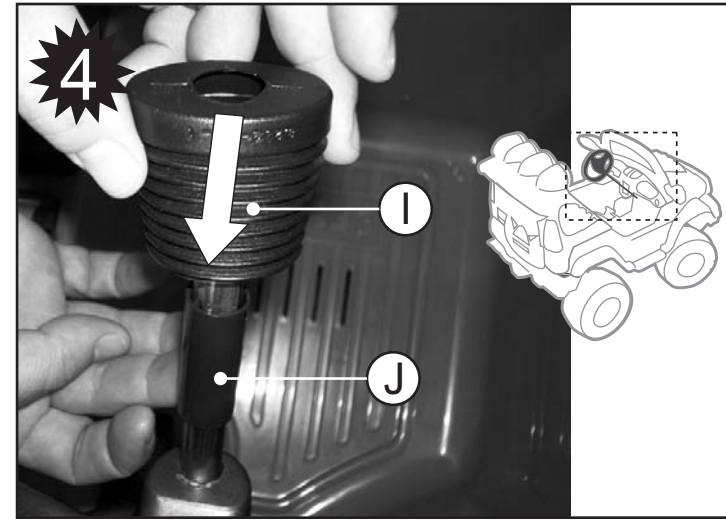
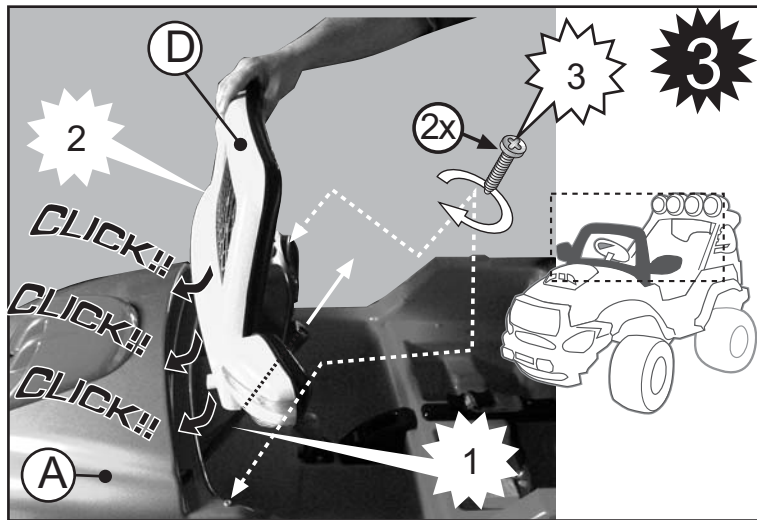
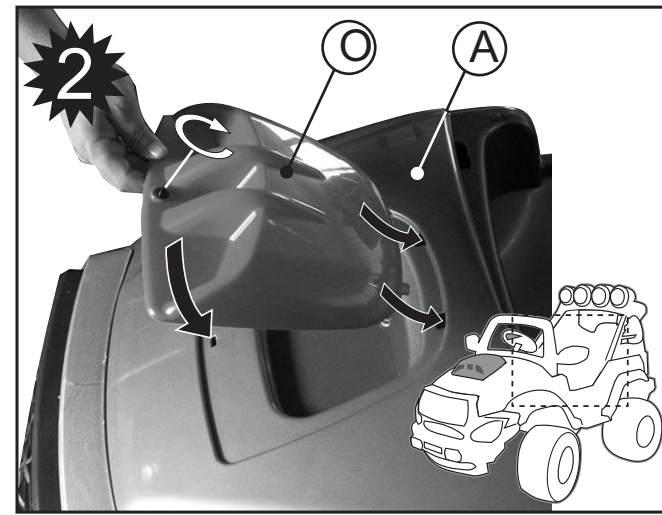
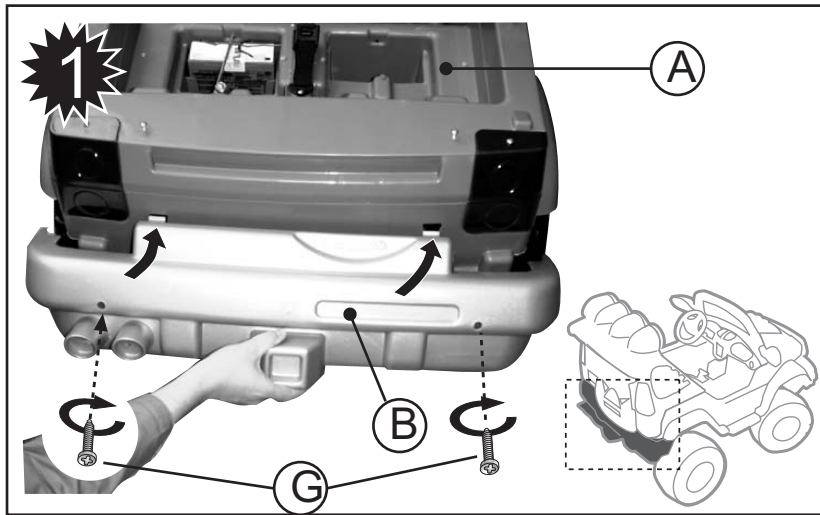

•INTERMITENTES • INDICATOR LIGHTS • CLIGNOTANTS  
 •BLICKLICHT • KNIPPERLICHTEN • PISCAS • INTERMITTENTI

•LUCES ACCELERACIÓN • ACCELERATION LIGHTS  
 •PHARES D'ACCELERATION • BESCHLEUNIGUNGSLICHTER  
 •VERSNELLINGSLICHTEN • LUZES ACELERAÇÃO  
 •LUCI ACCELERAZIONE

•FM RADIO

•SONIDO MOTOR • MOTOR SOUND  
 •SON DU MOTEUR • MOTORGERÄUSCH  
 •MOTORGELUID • SOM PISCAS  
 •SUONO INTERMITTENTI

•SONIDO INTERMITENTES • INDICATOR SOUND  
 •SON DES CLIGNOTANTS • BLICKLICHTGERÄUSCH  
 •GELUID KNIPPERLICHTEN • SOM PISCAS  
 •SUONO INTERMITTENTI

•CLAXON • HORN  
 •CLAXON • HUPE  
 •CLAXON • APITO  
 •CLAXON

**3X** **+** **-** **PILAS NO INCLUIDAS**  
**SIZE S** **BATTERIES NOT INCLUDED**  
**AAA - LR03 - 1,5 V. ALKALINE** **PILAS NON INCLUSES**  
**BATTERIEN NICHT INBEGRIFFEN**  
**BATERIEN NIET INBEGREPEN.**  
**PILHAS NÃO INCLUIDAS.**  
**PILE NON INCLUDE.**

