

130*200MM

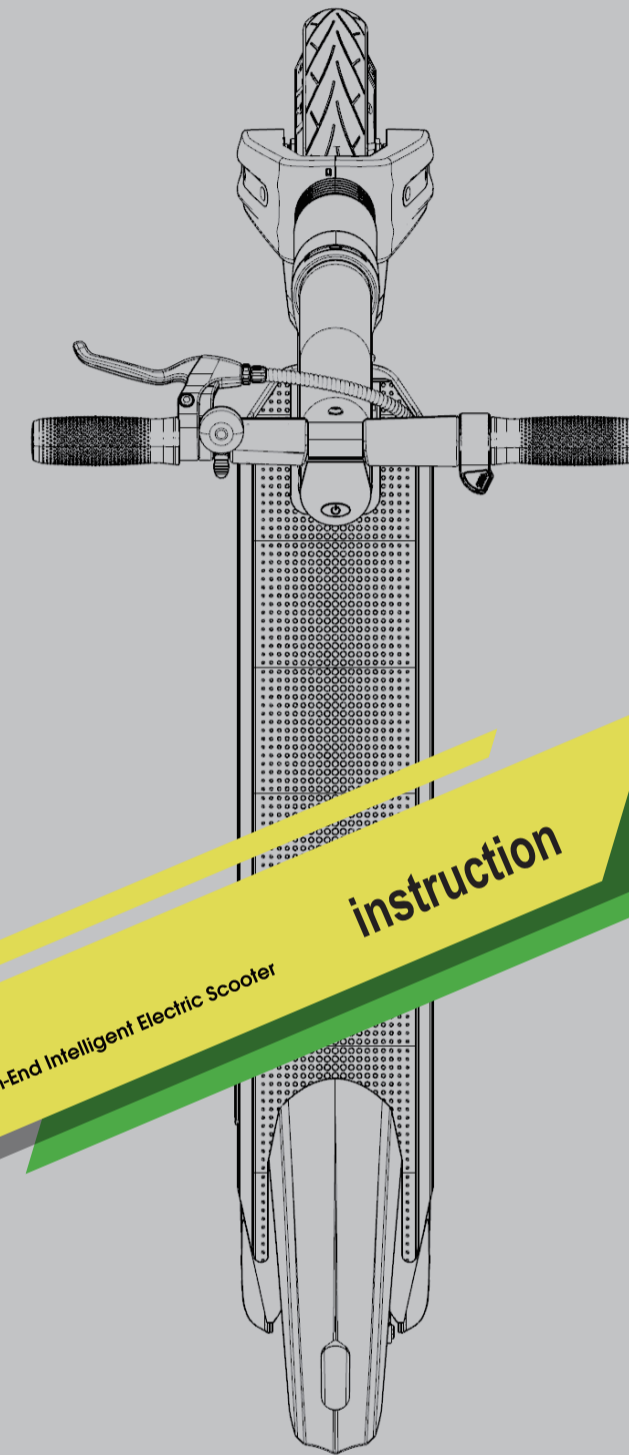

High-End Intelligent Electric Scooter



instruction
High-End Intelligent Electric Scooter

Contents

- 1. About ES200
- 1.1 Product Introduction
- 1.2 Product and parts
- 1.3 Product parameter

- 2. Product use
- 2.1 Schematic for Product
- 2.2 Entire Scooter Assembling
- 2.3 Operating instructions
- 2.4 Riding instructions
- 2.5 Quick Fold
- 2.6 Scooter Charging

- 3. Service and Maintenance
- 3.1 Routine Instructions
- 3.2 Charging Instructions
- 3.3 Battery Instructions

- 4. Quality Assurance

1

1. About ES200

1.1 Product Introduction

Thank you for your selection of ES200 Aluminium smart scooter. It is a fashionable, portable, leisure device which is ideal for recreational use. It has novel appearance, quick folding system and is portable and easy to carry. We are sure you will have fun riding the scooter.

1.2 Product and parts

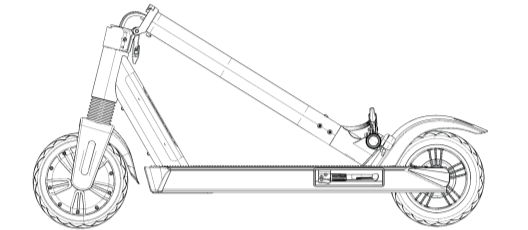

charger

Inner hexagon spanner

1.3 Product Parameter

ES200	
Unfolding size	1155*500*1188mm
G.W/M.W	23/21KG
Tyre Size	10 inch Solid tyre
Max load	100KG
Charging time	3-5h
Brake	Electromagnetic brake + mechanical drum brake
Motor	350W Brushless toothless motor
Color	Black

2

2. Product use

2.1 Schematic for Product

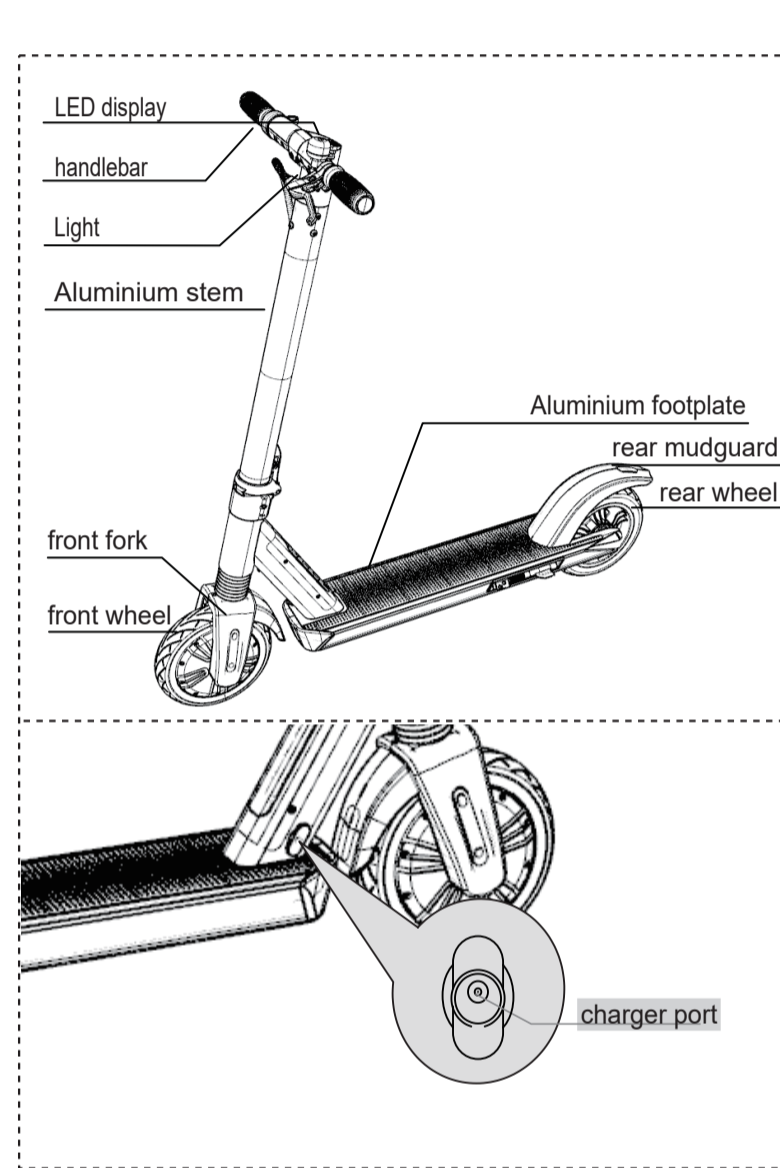

3

2.2 Entire Scooter Assembling

1. Place the scooter stably on the ground and hold up the front steering pipe and fix it by side button.

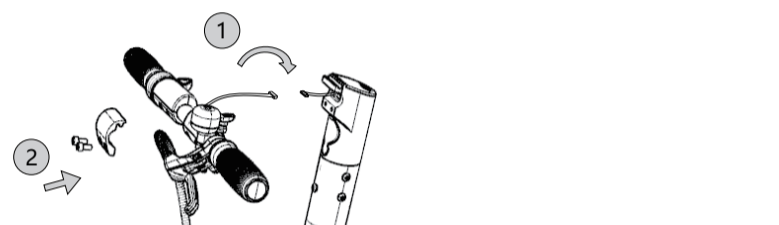
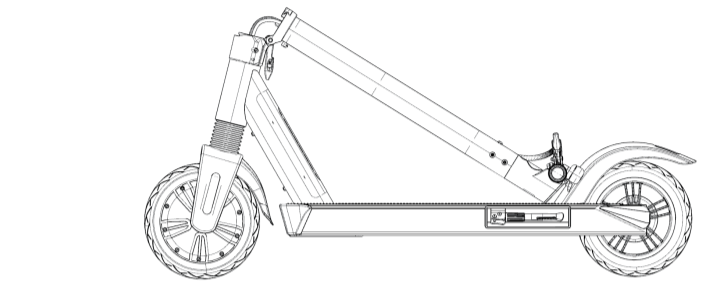

1. Insert the plug in parts then put the parts and wire into the whole carefully

2. Fix handlebar parts by screws as shown

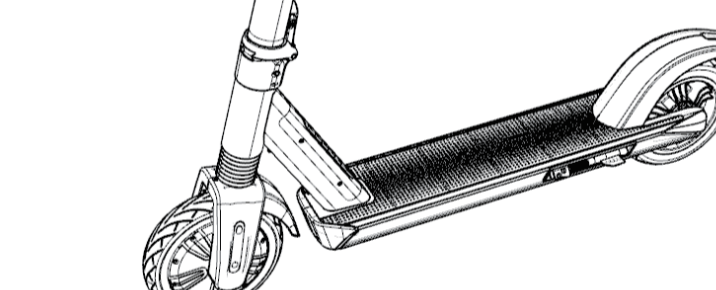

4

2.3 Operating instructions

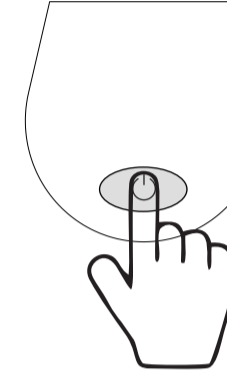

keep pressing the "on" button to turn on /off the scooter

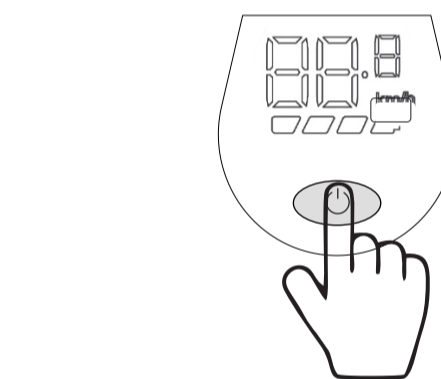
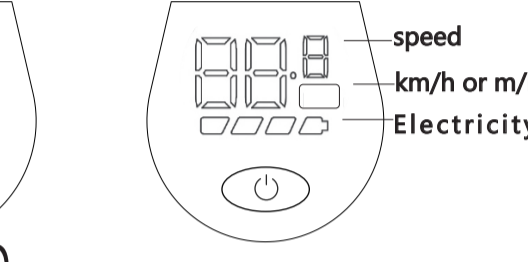

Press the "on" button twice to adjust the speed
Press the "on" button once to turn on the headlight

5

2.4 First ride instruction

In order to get used to the scooter as soon as possible, please choose an open and accessible place to ride for the first time. Check each part first before you use the scooter. Press the power switch first, and the dashboard lights up, indicating that the scooter is energized. Then slowly press your right hand to control the speed. Please check there is no lag in the process of moving forward. When you brake, press the brake lever to check whether the brake is sensitive or not. If all is normal, you can use the scooter safely.

2.5 Quick Fold

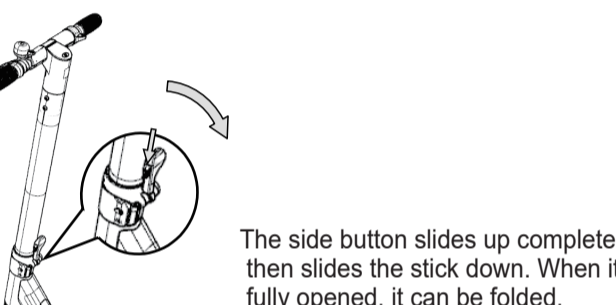

The side button slides up completely, then slides the stick down. When it is fully opened, it can be folded.

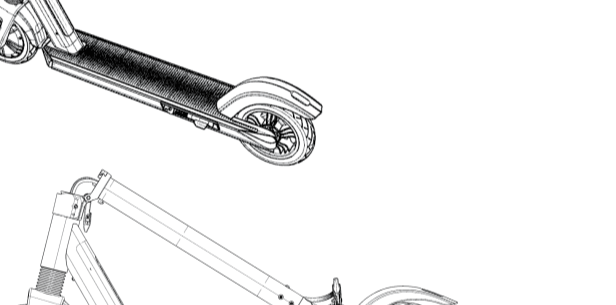

Fixed folding clasp, complete folding

6

2.6 Scooter Charging

1. When the input and output of the charger are connected, its red indicator comes on. The battery is full when the indicator light turns from red to green. At this time you can remove the charger and place the protective cover back.

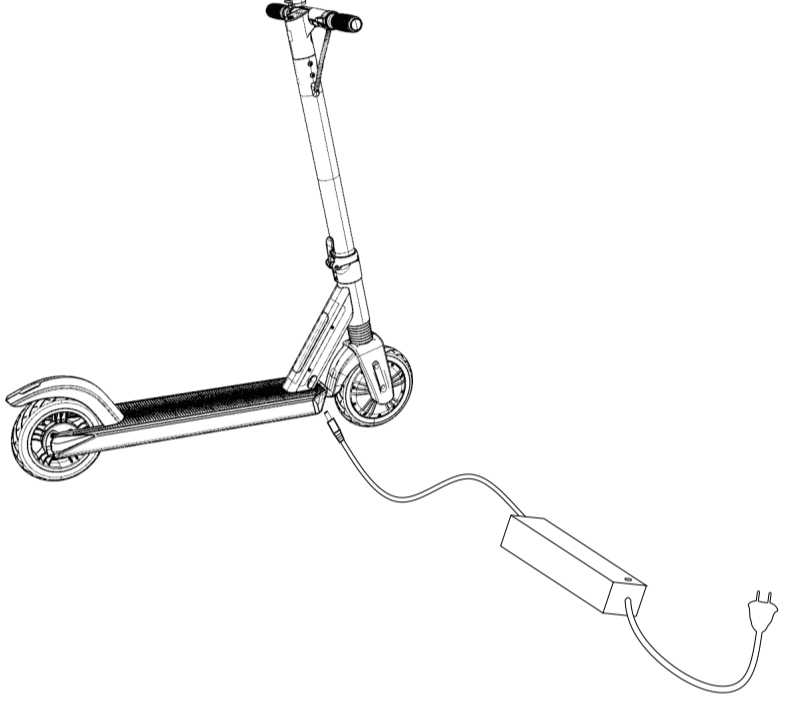

2. Standard Charging Time:
The scooter is charged for the specified period of time, about 3-5 hours, for the associated charger at ambient temperature between -10° C and 50 C.

3. This charger has an over charge protector, which will be damaged by large current input. The charging current must be less than 2A. Long-term charging at big current can damage the battery and hinder the lifespan of the battery.

7

3. Service and Maintenance

3.1 Routine Instruction

Do not use the electric scooter until you read the instructions carefully and understand the performance of the electric scooter. Don't lend to people who don't use electric scooters. Before using the electric scooter, check whether the fasteners of handlebar, wheels and folding are tight enough or not. Check whether the brake is effective.

1. Please use this scooter in a correct manner. To ride it safely, please wear personal protective equipment (including helmet, elbow, knee shield, etc.)
 2. Cleaning- use a soft rag on the scooter surface. Do not rinse it with water.
 3. Please slow down the scooter before travelling on a downward slope.
 4. Please do not use this scooter in rain, snow or through water, etc.
 5. Please do not use aftermarket parts like charger and other components not supplied by this company in order to avoid fault and incident.
 6. Do not tamper with this scooter. If the scooter is faulty, please contact local vendor or after-sales service office in time.
 7. Do not use this scooter in the area where no entry is allowed in all the national/local laws and by relevant units.
 8. Do not use this scooter in the place having risks or not meeting the product use requirements, such as deep pit, cracks, water pit with the depth of more than 3 cm, very uneven road, etc.
 9. Do not ride scooter across steps or stairs. Do not jump or ramp scooter in any case, for example, across a ridge.
 10. Do not allow any child under 16 and any old man above 65 to solely ride this scooter unless otherwise they are accompanied by their family member(s).
 11. Do not allow any pregnant woman, drunk man, mental disease patient, heart attack patient and limited active person to ride the scooter.
- This company will claim no responsibility for any fault or incident resulting from use of this scooter in breach of the above specification.

It is strictly prohibited in the on the motorway

8

3.2 charging instructions

1. Please place the safety cover back after the scooter when fully charged.
2. Please place the scooter out of reach of children during charging.
3. Please do not use any other brand or type of charger to charge this scooter. In addition, this charger is not suitable for charging other types of scooter or battery.
4. Please do not disassemble any faulty charger. Please contact local vendor or after-sales service office in time.

3.3 Battery Instructions

1. Please place the battery far from a fire or corrosive environment because it is flammable and explosive.
2. Please do not smear or remove the label from the battery case.
3. Please do not open the battery case to avoid the damage to the internal parts and contact local vendor or after-sales service office in time if the battery can not be charged.
4. In case of long-term disuse of this scooter, please charge the scooter periodically, i.e. every 20-30 days, to keep the battery in good conditions.

9

4. Quality Assurance

Thank you for your purchase of the product from us. Please observe the following regulations carefully to enjoy your benefit.

- Please note that no quality assurance will be provided in case of one of the following:
1. The quality assurance period has expired.
 2. The scooter fails because of misuse, lack of maintenance and adjustment in breach of the use instructions.
 3. The scooter is damaged due to improper use and storage or incident.
 4. The scooter is damaged because the user tampers with it, or its fault can not be technically identified and analyzed because the user disassembles it to change its original fault state.
 5. The scooter fails because the user does not use the original charger.
 6. The data on the item without effective invoice do not comply with the information.
 7. The scooter is damaged because of its contact with smoke, drug, chemical, water, etc.
 8. The electronic system of the entire scooter is damaged by moisture, rain, snow, etc.
 9. The scooter is damaged by act of God, including, but not only limited to flood, fire, lightning, earthquake, social event, etc.
 10. Consumables are not covered. Examples listed but not limited to lamp, display, brake disc, tyre, rubber part, plastic part, etc.
 11. The user is not satisfied with the scooter color, dimension, etc.

Scope of Quality Assurance		
Part Name	Warranty	Fault
Motor	Brushless motor 12 months	Irreparable repair because of phase loss and burning of winding, magnetic leakage from magnet steel, drop-out, wheel axle deformation, etc. except from water entry to the motor. Hubs and bearings have the quality assurance period of 6 months. In case of quality defect, they will be repaired in the first six months and replaced in the second 6 months.
Battery	Lithium battery 12 months	No quality assurance will be provided unless damaged by external force, with use of non-specified charger, etc. No quality assurance will be provided for battery repair. The battery is not quality repaired. No quality assurance period is provided for the replacement battery. The quality assurance period is a combined quality assurance period. The battery in which quality defect happens within 12 months is replaced and after 2 months warranty, with the corresponding quality assurance period of 12 months. If the battery has the capacity below 85% of the standard capacity in the quality assurance period, it is replaced with a maintenance battery with the capacity not lower than 85% of the standard capacity.
Charger	12 months	No surface crack resulting from external force, assembling, label removal or smearing, short circuiting, breaking, etc. with complete wire.
Control part	Controller 12 months	Quality assurance will be provided for quality defective except from assembling.
Power Drive part	Power Drive 6 months	No damaged surface, no broken wire, loss of power before protection, etc.
Frame	12 months	Quality assurance will be provided in case of loose weld or breakage except from external impact artificial damage.
Member	Handlebar 6 months	Natural cracking, breakage and case-wise deformation except from artificial deformation.
	Wheel rim 6 months	

10