

MINI MOTORCYCLE



OWNER'S MANUAL

Read and understand this entire manual before using!

NOTE: Manual illustrations are for demonstration purposes only.

Illustrations may not reflect exact appearance of actual product.

Specifications subject to change without notice.

OFF ROAD USE ONLY!!!

NEVER OPERATE THIS VEHICLE IF YOU ARE UNDER

AGE 12!!!

INTRODUCTION

Thank you for purchasing this product. The proper care and maintenance that your vehicle requires is outlined in this manual. Following these introduction will ensure a long trouble-free operating life of this vehicle and your satisfaction with it.

SAFETY WARNING

SAFETY WARNINGS

This vehicle is NOT A TOY and ONLY used in closed off areas remote from public road traffic.

Never permit children under age 12 to operate this vehicle.

Adult's supervision is required if children under age 16.

WARNING:

Riding this vehicle can be a hazardous activity. Certain conditions may cause the equipment to fail without fault of the manufacturer. Like other vehicles, the Mini Dirt Bike can and is intended to move, and it is therefore possible to lose control, fall off and/or get into dangerous situations that no amount of care, instruction or expertise can eliminate. If such things occur you can be seriously injured or die, even when using safety equipment and other precautions. **RIDE AT YOUR OWN RISK AND USE COMMON SENSE.**

This manual contains many warnings and cautions concerning the consequences of failing to maintain, inspect or properly use your mini dirt bike. Because any incident can result in serious injury or even death, we do not repeat the warning of possible serious injury or death each time such a possibility is mentioned.

APPROPRIATE RIDER USE AND PARENTAL SUPERVISION

This manual contains important safety information and use tips to help you and your child operate and handle the mini dirt bike. Carefully read the manual in its entirety together with your child before letting your child ride it for first time. The manual also contains important information on servicing the vehicle.

It is your responsibility to review the manual and make sure that all riders understand all warnings, cautions, instructions and safety topics and assure that the riders are able to safely and responsibly use this product and protect your child from injury. We recommend that you periodically review and reinforce the information in this manual with your child, and that you inspect and maintain your children's vehicle to insure their safety. **The recommended rider age of 12 years** is only an estimate, and can be affected by the rider's size, weight or skills. Any rider unable to fit comfortably on this vehicle should not attempt to ride it.

It is important and necessary to conduct the technical training for your child before first use. To get the training information, please contact the dealer who you purchase the vehicle from. Before your child complete the training, do not let your child use this vehicle.

Children often underestimate or fail to recognize the dangerous situation, you should make it clear to your child that should not, under any circumstances, operate the vehicle without supervision and that your child may only drive at speed that are commensurate with the child's riding ability and other road condition.

A parent's decision to allow his or her child to ride this product should be based on the child's maturity, skill and ability to follow rules.

Keep this product away from small children younger than age 12 and remember that this product is intended for use only by persons who are, at a minimum, completely comfortable and competent while operating the vehicle

Do not exceed **135lbs (60kgs)** total weight on this vehicle. Rider weight does not necessarily mean a person's size is appropriate to fit or maintain control of this vehicle.

Do not touch the brakes/motor/exhausts on your bike when in use as they can become very hot.

ACCEPTABLE RIDING PRACTICES AND CONDITIONS

Always check and obey any local laws or regulations which may affect the locations where the vehicle may be used.

Ride defensively. Watch out for potential objects that could catch your heel or force you to swerve suddenly or lose control. Be careful to avoid pedestrians, skaters, skateboards, scooters, bikes, children or animals who may enter your path, and respect the rights and property of others.

This vehicle is meant to be used only in controlled environments free of potential traffic hazards and not on public streets or sidewalks. Do not ride your vehicle in any areas where pedestrians or product traffic is present.

Do not activate the speed control on the hand grip unless you are on the vehicle and in a safe, outdoor environment suitable for riding.

The vehicle was manufactured for performance and durability but are not impervious to damage. Jumping or other aggressive riding can over-stress and damage any product, including this vehicle, and the rider assumes all risks associated with high-stress activity. Be careful and know your limitations. Risk of injury increased as the degree of riding difficulty increases. The rider assumes all risk associated with aggressive riding activities.

Never use headphones or a cell phone when riding.

Never hitch a ride with another vehicle.

Do not ride the vehicle in wet or icy weather and never immerse the vehicle in a water, as the electrical and drive components could be damaged by water or create other possibly unsafe conditions.

The vehicle is intended for use on flat, level ground without loose debris such as rocks or gravel. Wet, slick, bumpy, uneven or rough surfaces may impair traction and contribute to possible accidents. Do not ride the vehicle in mud, ice, puddles or water. Avoid excessive speed that can be associated with downhill rides. Never risk damaging surfaced such as a carpet or flooring by use of the vehicle in doors.

Do not ride at night or when visibility is limited

PROHIBITED ITEMS

- ★ Do not touch the brakes or engine when the vehicle is in use as they can become very hot.
- ★ This vehicle should use mixture of the unleaded gasoline and the two cycle engine oil. The volume ratio is 25:1. Do not use any degraded fuel (which smells sour) or fuel of wrong mixture ratio. It will cause a poor start, insufficient output or damage the engine.
- ★ Do not use 4 cycle engine oil. (Otherwise, it causes the plug to be degraded, the piston ring to seize or the muffler to be clogged)
- ★ Do not run the engine in a room or poor ventilated area. (the exhaust gas includes odorless but hazardous carbon monoxide.)
- ★ Do not put your fingers and other body parts near to the drive chain, steering system, wheels and all other moving components.
- ★ Do not store, spill or use any gasoline near a fire, stove, oven, boiler or other instruments which uses a pilot light or spark. (Otherwise, it may cause an explosion.)
- ★ Smoking is strictly prohibited while refilling the fuel
- ★ While the engine is running or while it remains hot soon after stopping, do not remove the Lid of the fuel tank or refill the fuel. (Before refilling the fuel, stop the engine and cool it down 2 minutes or more)
- ★ If any gasoline is spilled or smelled or any danger of explosion felt, do not run the engine.
- ★ Do not check any spark while keeping the spark plug removed.
- ★ Do not run the engine with the exhaust or air cleaner cover removed.
- ★ Do not touch any hot muffler or engine part. (Otherwise, it may cause a burn.)
- ★ When the engine runs, do not touch any spark plug cap or high tension cord. (Otherwise, it may cause an electric shock and harm your body.)
- ★ Never use alcohol or drugs before or while operating.
- ★ Your insurance policy may not provide coverage for accidents involving the use of this vehicle. Consulting your insurance agent before using this vehicle.

PROPER RIDING ATTIRE

Always wear proper protective equipment such as an approved safety helmet, elbow pads and kneepads. A helmet may be legally required by local law or regulation in your area. A long-sleeved shirt, long pants and gloves are recommended. Always wear athletic shoes, never drive barefooted or in sandals, and keep shoelaces tied and out of the way of the wheels, motor and drive system.

FAILURE TO USE COMMON SENSE AND HEED THE ABOVE WARNINGS INCREASES RISK OF SERIOUS INJURY. USE WITH APPROPRIATE CAUTION AND SERIOUS

ATTENTION TO SAFE OPERATION.

LOCATION OF WARNING STICKER



Sticker A is located on the left side of fuel tank.

ATTENTION!

FUEL STYLE: LEADLESS PETROL 90# AND TWO-STROKE ENGINE OIL MIXTURE RATIO 25:1. PLEASE STOP ENGINE WHEN FILLING PETROL.

	CAUTION FIRE RISK		CAUTION EXPLOSION
---	------------------------------	---	------------------------------

Sticker B is located on the rear fender.

 **WARNING**

-  **NEVER** operate this vehicle if you are under age 12
Adult supervision and instruction is required to operate this vehicle if you are under age 16

-  **NEVER** ride as a passenger.
Passengers can cause a loss of control, resulting in SEVERE INJURY or DEATH

-  **NEVER** use on public roads.
OFFROAD use only.

Sticker C is located on the rear fender

WARNING

Improper use of ATVs can cause SEVERE INJURY OF DEATH



ALWAYS USE AN APPROVED HELMET AND PROTECTIVE
NEVER USE ON PUBLIC ROADS
NEVER CARRY PASSENGERS
NEVER USE WITH DRUGS OR ALCOHOL

NEVER operate:
without proper training or instruction
at speeds too fast for your skills or the conditions on public roads – a collision can occur with another vehicle
with a passenger – passengers affect balance and steering and increase risk of losing control

Always:
use proper riding techniques to avoid vehicle overturns on hills and rough terrain and in turns.
avoid paved surfaces – pavement may seriously affect handling and control.
LOCATE AND READ OWNER'S MANUAL...
FOLLOW ALL INSTRUCTIONS AND WARNINGS.

Sticker D is located on the left side of engine

WARNING

Danger of burns The exhaust system gets very hot when the vehicle is driven. Allow the exhaust system to cool down. Do not touch hot components.

PIN LOCATION



PIN is stamp marked on an aluminum plate that is riveted on the steering column .
PIN means the Product Identify Number which is unique for each unit.

MAIN PARTS

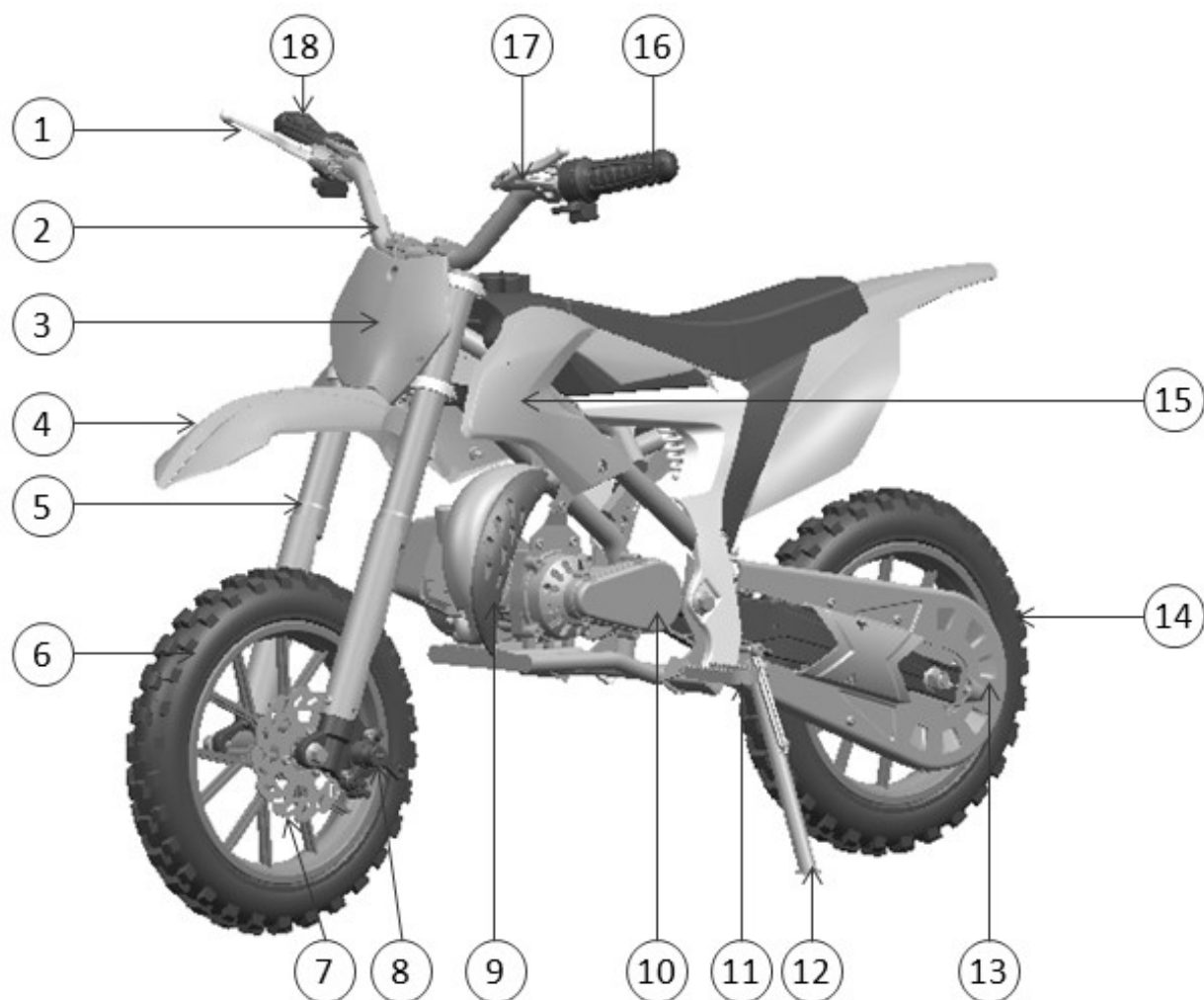

1: front brake lever

3: number plate

5: fork

7: front brake disc

9: exhaust heat-protection

11: footrest

13: chain cover

15: left plastic fairing

17: rear brake lever

2: handlebar

4: mudguard

6: front wheel & tire

8: front brake caliper

10: gear box

12: side stand

14: rear wheel & tire

16: handle rubber grip

18: throttle

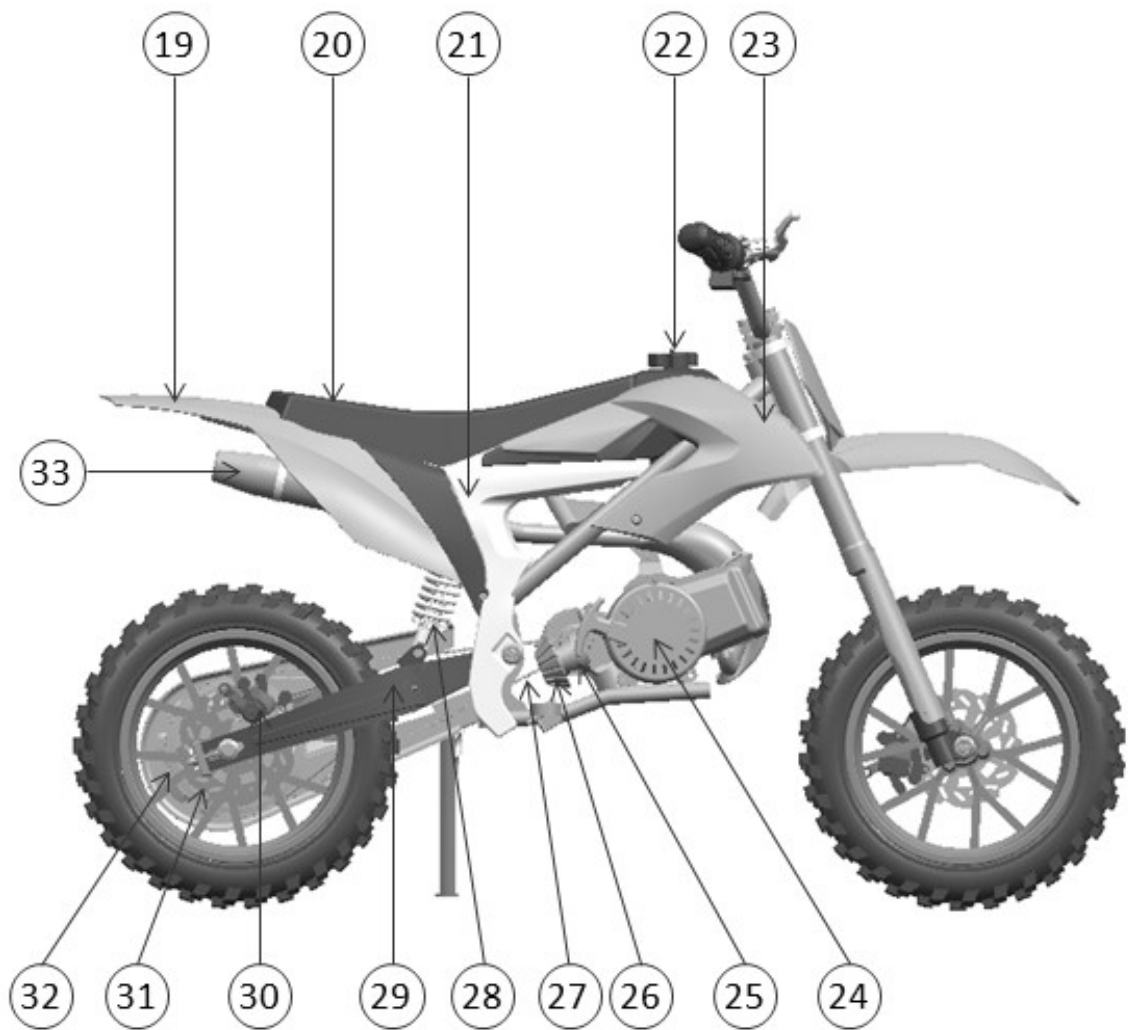

19: tail plastic body
21: plastic frame cover
23: right plastic fairing
25: carburetor
27: chain
29: swing arm
31: rear brake disc
33: exhaust

20: seat
22: fuel tank
24: engine pull starter
26: air filter
28: rear shock absorber
30: rear brake caliper
32: rear driven sprocket

HAND DRIVE CONTROLS



- 1 :rear brake lever
- 2 :engine stop switch
- 3 :front brake lever
- 4 : throttle handle

BEFORE YOU BEGIN

Remove contents from box. Inspect the contents of the box for scratches in the paint, dents or kinked cables that may occur during shipping. Because the product was 85 percent assembled and packed at the factory, there should not be any problems, even if the box has a few scars or dents.

Estimated Assembly and Set-Up Time

We recommend assembly by an adult with experience in motorbike or bicycle mechanics. Allow up to 30-40 minutes for assembly.

Required Tools

Some tools may be supplied; however, we recommend the use of mechanic's grade tools. Use the supplied tools only as a last resort.

The list of tool required is as follows

- Open end wrench 10mm / 13mm/ 17mm / 22mm
- Allen wrench 5mm / 6mm/ 8mm

Assembly illustration and instruction

ASSEMBLY HANDLEBAR

WARNING: Failure to properly adjust and tighten the bolts that affix the handlebar can cause you lose control and crash.



1. place the handlebar (A) in the bottom clamp, then cover the upper clamp (B) on the handlebar and install the 4pcs bolt (C)
2. Place the handlebar in the upright and vertical position, then tighten all the bolts securely with 10mm socket spanner.

- A: handlebar
- B: upper clamp
- C: bolt M8X20 4pcs

ASSEMBLY MUDGUARD

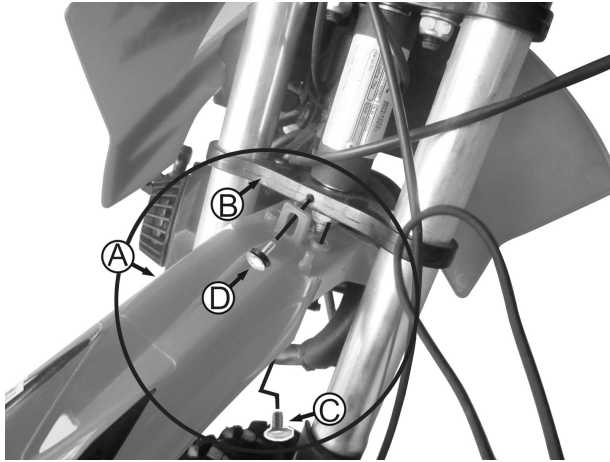

1. mount the bolt (D) through the mudguard fixing bracket into the splintage (B) and tighten it.
2. mount the bolt (C) bottom-up through the mudguard rear hole into the splintage (B) and tighten it.

A: mudguard
B: down splintage
C: bolt M6X16
D: bolt M6 x16

ASSEMBLYNUMBER BOARD

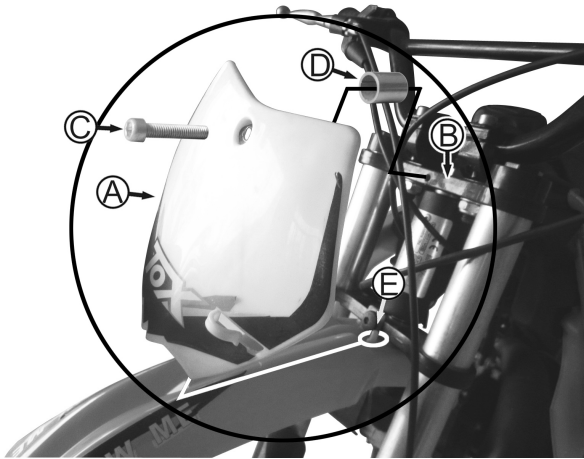

1. Fix the number board (A) into the location pillar of mudguard (E)
2. Install the bolt (C), bush (D) into the upper splintage (B) and tighten the bolt with 10mm socket spanner.

A: Number board
B: upper splintage
C: bolt M6X25
D: bush 8X1.0X15
E: location pillar

ASSEMBLY FRONT WHEEL AND REAR SHOCK ABSORBER



1. put the wheel (A) on the right position to place the disc (E) between the brake caliper pad.
2. mount the axle (B) through the left fork, bush (D), wheel, bush (D) and right fork in sequence, and then fix the nut (C) and tighten it.

A: wheel
B: wheel axle M12X160
C: nut M12
D: bush 16X1.2X13 2pcs
E: brake disc

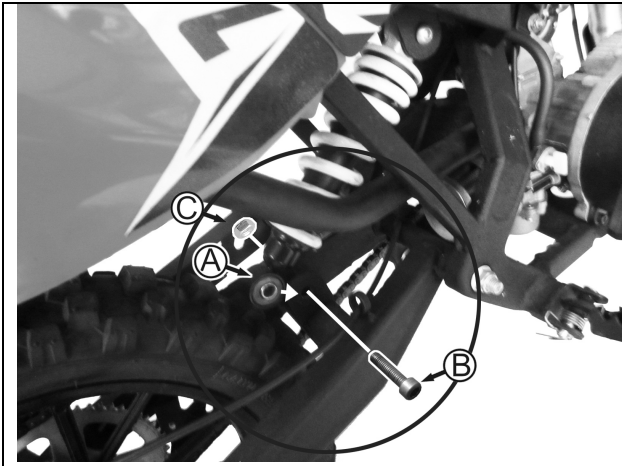

1. Uplift the frame to align the shock (A) mounting hole to the shackle joint hole.
2. Fix the bolt (B) through the shock mounting hole and shackle joint and tighten the nut (C) securely with 10mm and 13mm open end wrench

A: shock absorber

B: bolt M8X40

C: nut M8

INFLATING THE TIRES



NOTE: The tires are inflated when shipped, but they invariably lose some pressure between the point of manufacturing and your purchase. Always inflate the tires to the correct PSI before first time use.

Please read the specification sheet to get the information of tire pressure.

Using a bicycle-style tire pump to inflate the tire to the PSI indicated on the sidewall of the tire.

Note: The pressurized air supplies found at gasoline stations are designed to inflate high-volume automobile tires. If you decide to use such an air supply to inflate your tires, first make sure the pressure gauge is working, then use very short bursts to inflate to the correct PSI. If you inadvertently over-inflate the tire, release the excess pressure immediately.

Important information of use guider for tire

Note: Tire is the only contact between the vehicle to the road, the safety of various driving activity depends on the small area of tire where contact with the road. Therefore, it is very important to keep the tire in good condition any time and use the correct size and standard tire to replace the old ones.

Tire assembly and disassembly

It is strongly recommended that the tire assembly and disassembly should be done by an authorized technician with necessary skills.

Tire inflating pressure

It is very important to keep the tire in proper pressure and check the tire pressure before use. The inflating should be done while the tire is cold.

Tire maintenance

Tire tread depth should be checked regularly. (Shallower tread means less grip of tire). You

must stop to use the vehicle if the tire is pierced, disassemble the tire and check it carefully. Tire maintenance should be done by an authorized technician. Tire should be replaced immediately when it is distorted or damaged.

Tire replacement

It is important to use the correct size and standard tire as per our specification (see details in technical specification sheet)

Don't use the used tire if you are not sure its previous service condition.

Tire aging

Tire aging is unavoidable even the tire is not used. Tire aging is mainly reflected in the cracked section on side of tire and tire tread, sometimes the tire is distorted as well. The used and aged tire should be checked and confirmed if it is ok to use again by an authorized technician

TECHNICAL SPECIFICATION SHEET

Engine type	single cylinder, 2 stroke, forced air cooling
Power output	1.6kw/7500rpm
Max torque	2.0 N.m/3600rpm
Displacement (ml)	44
Fuel	Petrol mixed with 4% 2-stroke engine oil
Compression Ratio	7.5 : 1
Transmission	automatic with centrifugal clutch
Start method	manual pull start
Max.speed (km/h)	40
Front suspension	Telescopic fork
Rear suspension	mono shock absorber
Tyre	front & rear 2.50-10 with 4.00 P.s.i operation pressure and 36 P.s.i Max. inflate
Brake system	front and rear disc brake with mechanical control
Fuel tank capacity	1.6L
Dry Weight (KG)	24
Dimension (mm)	1240x570x780
Seat height (mm)	580
Carton size (mm)	1045x320x550

SAFETY REMINDERS

PRE-RIDE CHECKLIST

Loose Parts

Check and secure all fasteners before every ride. Make sure steering stem clamp bolts are locked properly in place. There should not be any unusual rattles or sounds from loose parts or broken components. If you are not sure, ask an experienced mechanic to check.

Brake

Check the brake for proper function. When you squeeze the lever, the brake should provide positive braking action.

☐ Frame, Fork and Handlebars

Check for cracks or broken connections. Although broken frames are rare, it is possible for an aggressive driver to bash into a curb or wall and wreck and bend or break a frame. Get in the habit of inspecting yours regularly.

☐ Tire Inflation

Periodically inspect the tires for excess wear, and regularly check the tire pressure and re-inflate as necessary. If you get a flat tire, the inner tube can be patched or a new tube can be purchased from an authorized repair shop.

☐ Safety Gear

Always wear proper protective equipment such as an approved safety helmet, elbow pads and kneepads. Always wear shoes (lace-up shoes with rubber soles), never drive barefooted or in sandals, and keep shoelaces tied and out of the way of the wheels, motor and drive system

ATTENTION

We recommend checking all tightenings after the first time use. Special attention should be paid to the following parts:

- Footrest
- Engine sprockets (Racing version only)
- Shock absorber
- Engine bolts and nuts
- Rear sprocket

ECOLOGIC DRIVE

The noise and the pollution of every vehicle depend on how it is driven.

We strongly recommend you to drive steadily, without strong acceleration and deceleration

During off road use, do not damage the environment, avoid noise and everything that can disturb persons and animals.

Use a sport drive only on race circuits.

● Checks and maintenance before and after off-road use

In order to avoid problems connected to the operation of the vehicle, it is advisable to perform a number of checks and maintenance operations before and after use. Just a few minutes given to these procedures will save you time and money, and will make riding much safer.

Proceed as follows:

- Check tire pressure, general condition and thickness of tread.
- On cold days, warm up the engine by running it at idle speed for a few minutes before starting off.
- Wash the vehicle carefully after every off-road use.

REPAIR AND MAINTENANCE

● Fueling operations

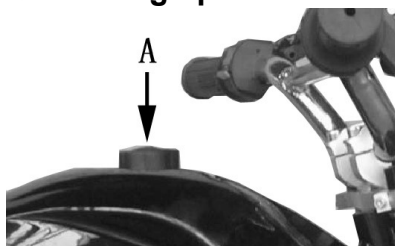

Remove cap A.

The fuel tank will hold approximately 1 liter.

Only use green fuel mixture with 4% oil.

● Breaking in

During the first 25 hours of operation running-in), the following precautions should be used;

- Avoid travel at high speeds
- Change speed often so that the parts will break in uniformly and in a shorter time
- Avoid turning the throttle more than 3/4 of the way.

Warning:

- Change the crankcase oil after 500km.
- Always use a mixture of green grade gas and a qualitatively good oil.
- After the first off-road use, check all of the nuts and bolts.

● Startup

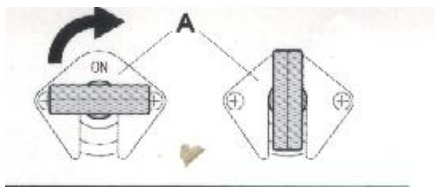

Manual hand pull

-Open fuel tank valve **A**

ON = open

-Sharply pull on the starter as shown in the figure while slightly turning the throttle twist grip.

-Always close the fuel tank valve when the engine is off.

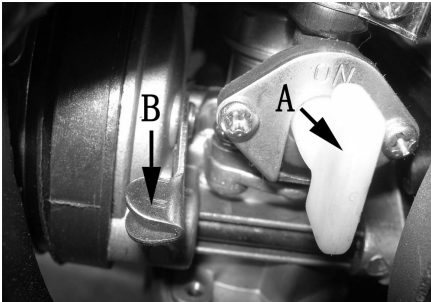

Note:

With the engine cold, act on the starter by pushing up lever **B**, start the engine and wait for a short, then reposition the lever to its former position.

● AIR FILTER

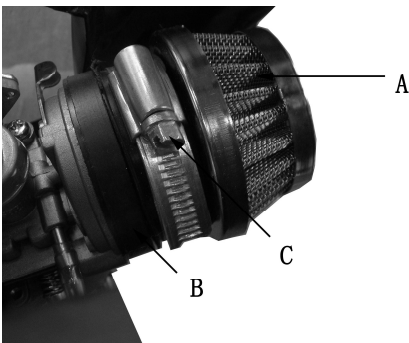

Air filter **A** is located under the rear shock absorber, and is directly connected to the carburetor by rubber manifold **B**.

To remove the filter, loosen clamp screw **C**, then pull out the filter and clean it.

Note: If the filter is very dirty, first wash it with petrol and then with water and soap.

Clean the filter every time the vehicle is used in cross country.

● SPARK PLUG

Keeping the spark plug in good condition will reduce fuel consumption and increase engine performance.

To perform the check, simply slide off the electrical connection tube and unscrew the spark plug.

Examine the distance between the electrodes with a feeler. This distance should be from 0.5 to 0.6 mm. If it is not, it may be corrected by bending the earth electrode.

Check as well that there are no cracks in the insulation or corroded electrodes. If so, replace immediately.

When replacing the spark plug, screw it in by hand until it stops, then tighten with a wrench.

Adjusting chain

Checking the drive chain periodically to ensure longer chain life.

Always keep it lubricated and tighten the chain as follows:



Step 1: Use the cross screwdriver to loose the 3pcs screws and remove the chain cover

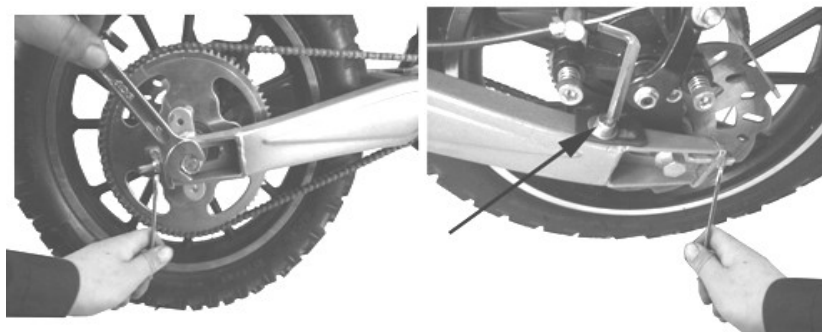

Step 2: Loose the rear wheel axle nut with 17mm and 14mm open spanner, then loose the screw of caliper bracket, adjust the chain adjuster.

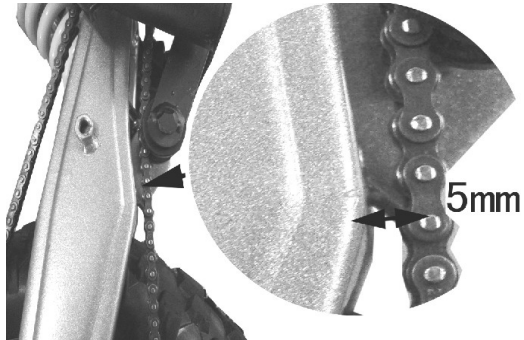

Step 3: The chain tension is in good condition while the gap is about 5mm between chain to lowest parts of swing arm. Lock all the nuts and screws, check the wheel alignment and then re-attach the chain cover.

Adjusting brake



Step 1:

To adjust the brake tension, thread the brake lever adjuster in or out 1/4 or 1/2 turn until the required brake adjustments is attained.

Most of brake adjustments are complete at this step, if the brake still need the further adjustment,

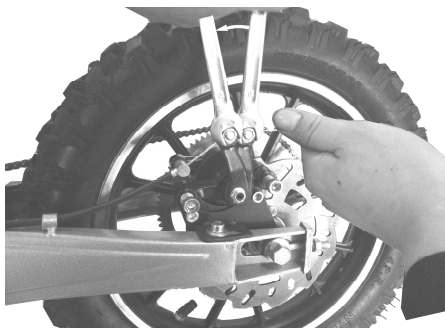

Step 2:

With 10mm open spanner, loose the brake cable and adjust the brake caliper arm to make the cable length >30mm from arm to the pillar.

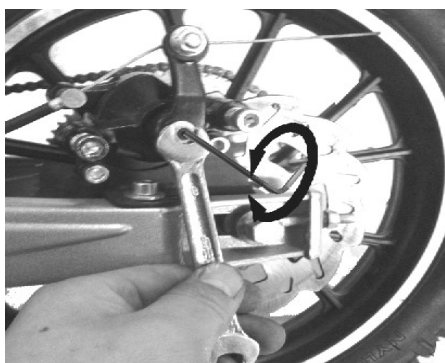

Step 3:

With 8mm open spanner to loose the nut of friction pad, and with 2.5mm allen wrench to adjust the inner screw for friction pad.

Check

To check the wear of front and rear brake pads **A**, simply inspect the brakes calipers as shown

in the below picture.

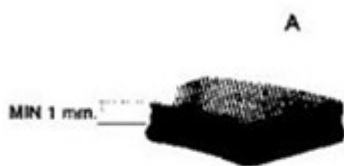

The thickness of the lining on the ends of the four pads should never be less than 1mm.

Should the lining be thinner, immediately replace the brake pads.

We recommend having the brake pads replaced by an authorized dealer.

Warning:

The brake is capable of causing the bike to skid the tire throwing an unsuspecting rider. Practice in an open area free from obstacles until you are familiar with the brake function. Avoid skidding to stop as this can cause you lose control or damage the rear tire.

Testing the Brakes

To use the brake, squeeze the lever to increase the pressure on the brake. The brake lever is fitted with a cable adjuster to compensate for cable stretch and/or to fine-tune the lever movement to brake engagement. If brake is not engaging properly, follow instructions for adjusting the brakes.

Chain and sprocket

The chain will typically have a “loose spot” and “tight spot” corresponding with a particular sprocket rotational position. This is normal and common to all chain-driven products due to run-out to tolerance of the free wheel and sprocket. The chain should be adjusted to the ideal tension with chain in the tightest spot.

Proper chain alignment must be maintained. The wheel must not be skewed, if the chain is noisy or rough running, check the lubrication, tension and alignment of sprockets, in that order.

Warning:

To avoid a pinch or injury, keep fingers away from moving sprockets and chain.

● CHECKS AFTER CLEANING

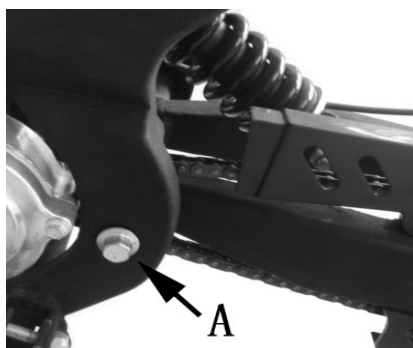

After cleaning the motorcycle, it is good practice to:

- Lubricate the articulated joints **A** on the rear suspension.
- Carefully clean and dry the chain-gear-position assembly and then apply grease thoroughly in order to keep these parts in good condition as long as possible.
- Dry well any metal parts subject to corrosion, oxidation, etc.

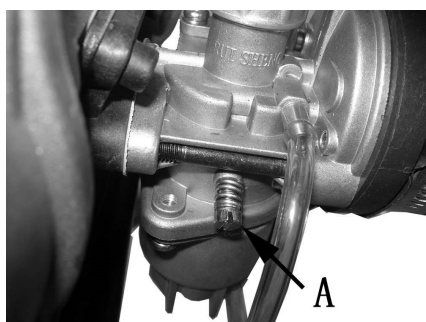

ADJUSTMENT OF IDLING SPEED

In order to perform this operation correctly, we advise you to do it when the engine is hot, connecting an

electric revolution counter to the spark plug wire. Then use a screwdriver on register screw **A** to calibrate the minimum.



● **CAUTION**

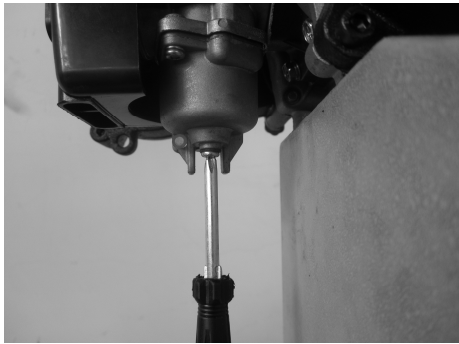

ADJUSTMENT OF GAS CLEARANCE

If the throttle control idle travel exceeds 3 mm as measured on the rim of the twist grip, Perform the adjustment by lifting dust cap **B**.

Always release the remaining fuel from the carburetor after use every time following the below steps

1. use a screwdriver to screw out the drain plug at the bottom of carburetor.
2. release the remaining fuel.
3. use a screwdriver to tighten the drain plug securely.

TROUBLESHOOTING

PROBLEM	CAUSE	REMEDY
The engine doesn't start	-Fuel system(tubes, fuel tank, valve) is blocked	Clean the system
	-No current arriving at spark plug	Clean or replace spark plug. If the problem persists, consult one of our Authorized Dealers
	-Engine is flooded	With gas completely open, continue trying to start engine for a few Moments. If engine still doesn't start, remove the spark plug and dry it off.
Engine misfires	-Spark plug has irregular electrode distance	Restore correct distance
	-Spark pug is dirty	Clean or replace
Engine overheats and loses power	-Silencer partially obstructed	Contact an authorized dealer
	-Exhaust clearance partially obstructed	Contact an authorized dealer
	-Mix too lean	Jet may be partially obstructed
	-Delayed ignition	Contact an authorized dealer
Weak brake	-Worn Brake pads	Contact an authorized dealer

CIRCUIT DIAGRAM

Diagram Circuit

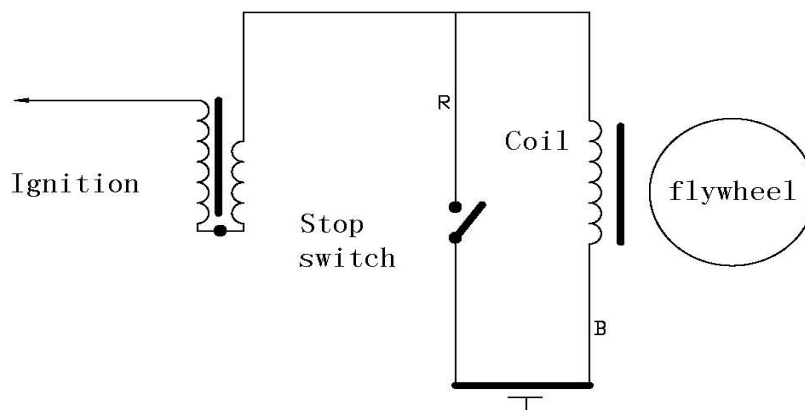

R: Red
B: Black



Please read the owner's manual before riding.



Never operate this vehicle if you are under age 12.



Never use the vehicle on public road. OFF ROAD use only.



Never ride with a passenger



Always use an approved helmet and protective gear



NEVER use with drugs or alcohol



Cold tire pressure.